

EXTENSION ACTIVITY
GENERAL CHEMISTRY

LEWIS STRUCTURES

Activity Directions

i

This activity will serve as practice for the topics covered in the Lewis Structures game. This activity is best used in conjunction with not only the tutorial levels, but also supplementary learning resources such as course lectures, textbook reading, etc. Questions labeled “Lock It In” are simply opportunities for you to solidify what you have accomplished in each task and help ensure you meet each objective.

1. Log into Collisions and navigate to the Lewis Structures Game.
2. Play the Tutorial levels, if you haven't done so already.
3. Exit the levels and enter the Lewis Structures sandbox.
4. Follow all instructions as written below. Be sure to reference your course's textbook, lecture notes, etc. as needed.



OBJECTIVE 1

Demonstrate an understanding of binary molecular compound nomenclature.

The naming of molecular compounds can be a rather complex art due to the huge diversity of compounds that exist, particularly those involving carbon. However, the nomenclature is far simpler when dealing with binary molecular compounds since these compounds only contain two elements. In fact, binary molecular compound nomenclature shares some similarities with ionic compound nomenclature and will appear familiar if you have already mastered that skill.

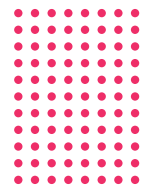

Step 1: Ensure that you have the correct chemical formula for the compound.

The correct chemical formula of the compound will tell us not just which elements are contained in it, but it also indicates the correct prefixes and naming sequence. To ensure you have the correct chemical formula the elements must be ordered with the **least** electronegative element being listed first. There are, however, exceptions to this rule. For example, **carbon should be listed first** regardless of electronegativity, and nitrogen should appear before hydrogen, despite its higher electronegativity.

TASK 1: Use the electronegativities on the periodic table below to determine the proper sequence of the following common nonmetals: fluorine (F), iodine (I), bromine (Br), sulfur (S), oxygen (O), and chlorine (Cl) in the spaces below. Elements that are provided are exceptions to the general rules.

Written First

C	P	N	H						
---	---	---	---	--	--	--	--	--	--

 Written Last



OBJECTIVE 1

Demonstrate an understanding of binary molecular compound nomenclature.

Pauling Electronegativities of the Elements

Group (vertical)	1	2	3	4	5	6	7	8	9	10	11	12	13	14	15	16	17	18
Period (horizontal)																		
1	H 2.20																	He
2	Li 0.98	Be 1.57											B 2.04	C 2.55	N 3.04	O 3.44	F 3.98	Ne
3	Na 0.93	Mg 1.31											Al 1.61	Si 1.90	P 2.19	S 2.58	Cl 3.16	Ar
4	K 0.82	Ca 1.00	Sc 1.36	Ti 1.54	V 1.63	Cr 1.66	Mn 1.55	Fe 1.83	Co 1.88	Ni 1.91	Cu 1.90	Zn 1.65	Ga 1.81	Ge 2.01	As 2.18	Se 2.55	Br 2.96	Kr 3.00
5	Rb 0.82	Sr 0.95	Y 1.22	Zr 1.33	Nb 1.6	Mo 2.16	Tc 1.9	Ru 2.2	Rh 2.28	Pd 2.20	Ag 1.93	Cd 1.69	In 1.78	Sn 1.96	Sb 2.05	Te 2.1	I 2.66	Xe 2.60
6	Cs 0.79	Ba 0.89	*	Hf 1.3	Ta 1.5	W 2.36	Re 1.9	Os 2.2	Ir 2.20	Pt 2.28	Au 2.54	Hg 2.00	Tl 1.62	Pb 2.33	Bi 2.02	Po 2.0	At 2.2	Rn 2.2
7	Fr 0.7	Ra 0.9	**	Rf	Db	Sg	Bh	Hs	Mt	Ds	Rg	Uub	Uut	Uuq	Uup	Uuh	Uus	Uuo
Lanthanides	*	La 1.1	Ce 1.12	Pr 1.13	Nd 1.14	Pm 1.13	Sm 1.17	Eu 1.2	Gd 1.2	Tb 1.1	Dy 1.22	Ho 1.23	Er 1.24	Tm 1.25	Yb 1.1	Lu 1.27		
Actinides	**	Ac 1.1	Th 1.3	Pa 1.5	U 1.38	Np 1.36	Pu 1.28	Am 1.13	Cm 1.28	Bk 1.3	Cf 1.3	Es 1.3	Fm 1.3	Md 1.3	No 1.3	Lr 1.291		

Electronegativity Values, [CC BY-SA 3.0](https://creativecommons.org/licenses/by-sa/3.0/)



OBJECTIVE 1

Demonstrate an understanding of binary molecular compound nomenclature.

LOCK IT IN:

Identify the compounds that are written incorrectly using the sequence you determined in Task 1. Correctly write the chemical formulas in the second column. Note that not all are written incorrectly. If the chemical formula is already correctly written, simply rewrite it the same way in the second column.



i

Chemical Formula	Correct Chemical Formula
OH ₂	
OF ₂	
F ₆ S	
PCl ₃	
H ₄ C	

Step 2: Identify the correct prefixes and modify the names of the elements as necessary.

Binary Molecular Compound Prefixes

Number of Atoms	Prefix	Number of Atoms	Prefix
1	mono-	6	hexa-
2	di-	7	hepta-
3	tri-	8	octa-
4	tetra-	9	nona-
5	penta-	10	deca-



OBJECTIVE 1

Demonstrate an understanding of binary molecular compound nomenclature.

Now that you know the chemical formula of the compound, you can simply list the name of the first element if there is only one atom of it in the compound. You will **never** add the prefix for one, “mono-”, to the name of the first element. However, if there is more than one atom of that element, you **should** add the correct prefix from the table on the previous page.

The second element is named by taking the stem of the element name and adding the suffix *-ide*. This second element will receive one of the prefixes from the table on the previous page. Please note that if the prefix ends in a vowel and the element that follows it starts with one, the vowel at the end of the prefix is typically removed (e.g. tetra**a**fluoride but tetra**o**xide).

Examples

ClF is **chlorine monofluoride** (notice that it is NOT **monochlorine monofluoride**)

Cl₂O is **dichlorine monoxide**

P₄S₃ is **tetraphosphorus trisulfide**

Please note that some binary compounds have common names that are used far more than the names they would have with this method. For example, water is almost never called dihydrogen monoxide* despite its chemical formula being H₂O, nor is ammonia often called nitrogen trihydride despite its chemical formula of NH₃.

TASK 1: Correctly name the compounds in the table when given the chemical formula and vice versa.

Chemical Formula	Chemical Name
	Selenium dichloride
P ₃ N ₅	
S ₄ N ₄	
S ₂ O ₂	
	Dibromine trioxide

*Visit www.dhmo.org to see how a little chemistry knowledge can spare you unnecessary anxiety.



OBJECTIVE 1

Demonstrate an understanding of binary molecular compound nomenclature.

LOCK IT IN:

Complete the table below by determining the chemical formula and chemical name of each structure.

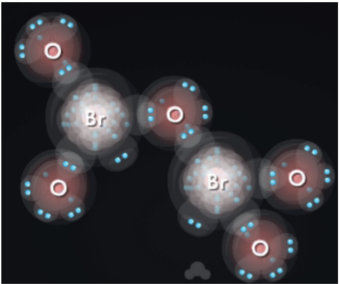
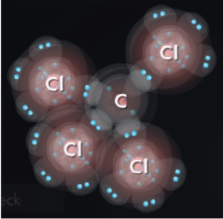
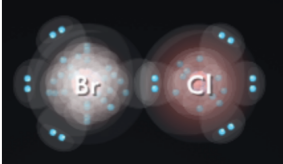
Compound Structure	Chemical Formula	Chemical Name
		
		
		
		

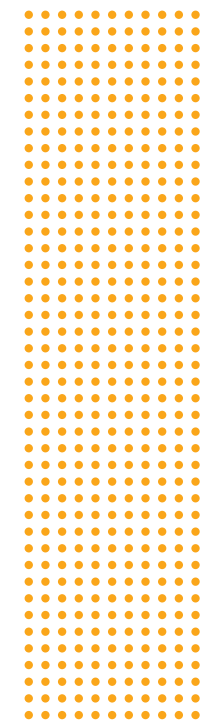



OBJECTIVE 2

Demonstrate an understanding of how Lewis structures are built for molecular compounds.

Lewis structures are a useful tool commonly used in chemistry to simply depict the valence electrons found around atoms and ions. As such, Lewis structures can also be used to show how atoms interact with one another in order to fulfill the **octet rule** (or **duet rule** for hydrogen) that states that atoms generally prefer to have a full set of valence electrons. Such a state would be represented on a Lewis structure by showing some combination of **lone pairs** and **bonding electrons** surrounding the atom that totals to eight electrons.

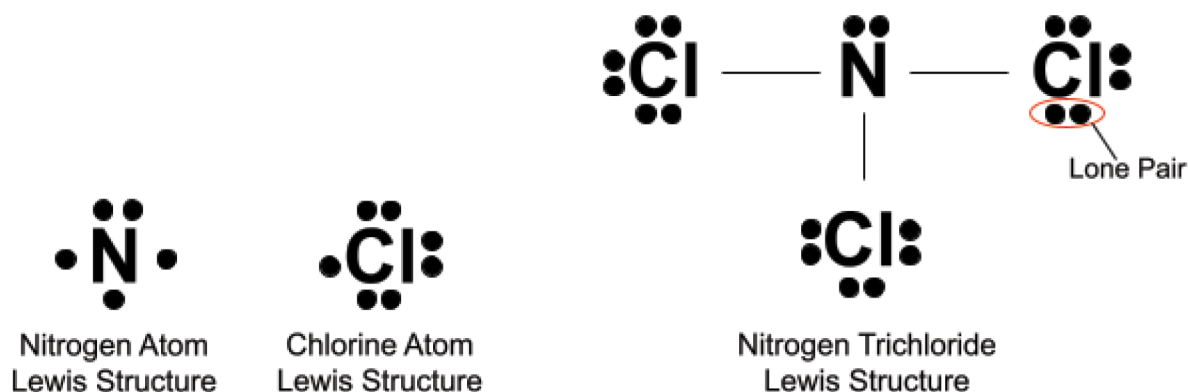
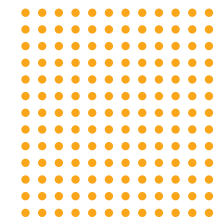

Notice how dots are used to represent unbonded electrons, and a connecting line is used to represent a PAIR of bonding electrons. Counting up all of the lone pairs and bonding electrons around each atom in nitrogen trichloride yields the number eight. This demonstrates that this arrangement of electrons satisfies the octet rule.

*Note that dots can also be used to represent bonding electrons as well. These are known as “complete” Lewis structures while the use of lines is considered “simplified”.

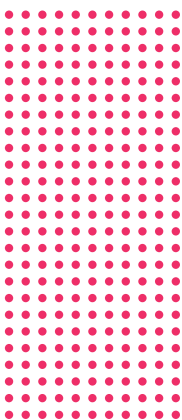



OBJECTIVE 2

Demonstrate an understanding of how Lewis structures are built for molecular compounds.

The structures that you built during the Lewis Structures Game were exactly that– Lewis structures. Traditionally, however, Lewis structures do not indicate the three-dimensional structure of the molecule. In this way, they are more similar to the initial structure that you constructed before it was checked by the game than the structure that appears in the bottom panel. The final structure in the bottom panel uses a concept that will be discussed later in this activity to give the molecule a more realistic shape.

Construction of Lewis structures for covalent compounds is very important in chemistry. The process can be described in just a few steps, but it can certainly take a fair amount of time to construct one, depending on the complexity of the molecule.

Step 1 - Skeletal Structure

It is first necessary to arrange the atoms so that bonds can be made to connect them. Fortunately, determining the atom to appear in the center follows similar guidelines as determining which element should be listed first in the chemical name– the least electronegative element should go in the middle. The main exception is hydrogen, which is never the central atom due to the fact it forms a duet instead of an octet and thus cannot make more than one bond. In the case that you only have two atoms in your compound, a central atom does not exist. There are exceptions to these patterns, and often the element with the most bonding sites will be in the center regardless of electronegativity.

CO₂ - Carbon Dioxide



Carbon is less electronegative than oxygen, has more bonding sites than oxygen, and goes first in our naming rules, so we put it in the center.



OBJECTIVE 2

Demonstrate an understanding of how Lewis structures are built for molecular compounds.

Step 2 - Count the Total Number of Valence Electrons

Count up the total number of valence electrons in the molecule of interest. Be sure to count the electrons for each individual atom and not just the elements with which you are working.

Element	Total Number of Atoms	Number of Valence Electrons Per Atom	Total Number of Valence Electrons in Structure
Carbon	1	4	4
Oxygen	2	6	12
Valence Electron Total:			16

Step 3 - Organize the Electrons

Connect the atoms with single bonds and then surround the terminal (outside) atoms with lone pairs before moving on to the central atom. Once you have done this, check to make sure that each atom has a complete octet (or duet in the case of hydrogen) and then move some of the lone pairs to make double and triple bonds as necessary.

*Note that we might have chosen to create something unsymmetrical, which would result in one triple bond and one single bond. While that is not ideal for reasons that will be discussed in Objective 4, it is important to note that it is still a valid Lewis structure that obeys the octet rule.

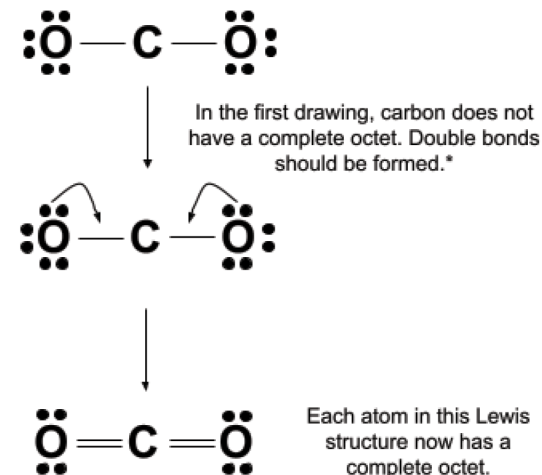



OBJECTIVE 2

Demonstrate an understanding of how Lewis structures are built for molecular compounds.

TASK 3: For each compound named in the table below, write out the chemical formula, sum up valence electrons, and then **draw** the Lewis structure. **After you finish the Lewis structure, construct what you have created in the sandbox to confirm that all of your bonds are correct.**

Chemical Name	Chemical Formula	Total # of Valence Electrons	Lewis Structure
Phosphorus tribromide			
Sulfur monoxide			
Oxygen difluoride			
Dinitrogen			



OBJECTIVE 3

Demonstrate an understanding of resonance structures and their relationship to resonance hybrids.

TASK 4: Draw two different, yet still correct, Lewis structures for the molecule **trioxygen**, better known as **ozone (O₃)**. Once you have drawn both structures, create both in the sandbox to verify the validity of each. It might help to revisit tutorial level 5 in the game for help building them.

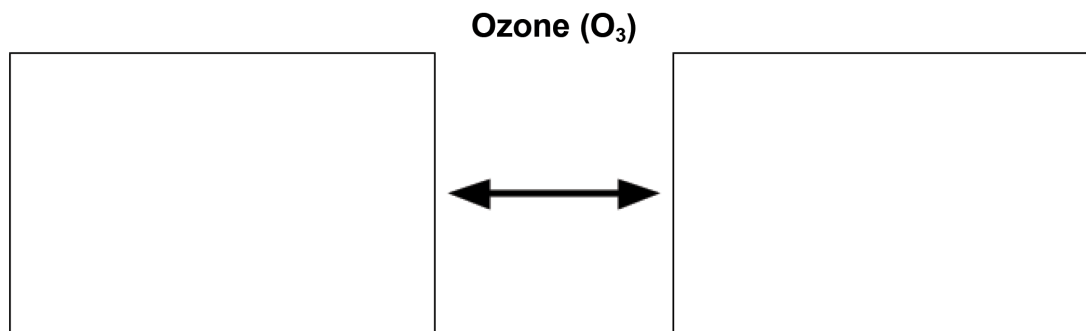

Both of the Lewis structures that you have created (assuming you verified them in the sandbox) are valid. These multiple, correct Lewis structures for a molecule are known as **resonance structures**. One might assume that a collection of ozone molecules would represent a mixture where some of the molecules are like one Lewis structure and the rest are like the other. However, the reality is that each individual ozone molecule is more like an average of the two structures. Each bond between the oxygen atoms is somewhere between a single and double bond in its character.

It might help to imagine that a Standard Poodle and Labrador Retriever have a litter of puppies. The litter would not be a mixture of individual Poodle puppies and individual Labrador Retriever puppies. Instead, ALL of the puppies would be Labradoodles. This same effect is seen in molecules with multiple resonance structures, and the intermediate character of these molecules leads us to create Lewis structures known as **resonance hybrids**. The intermediate bonds in these hybrid structures are typically represented by one solid line and one dashed one.

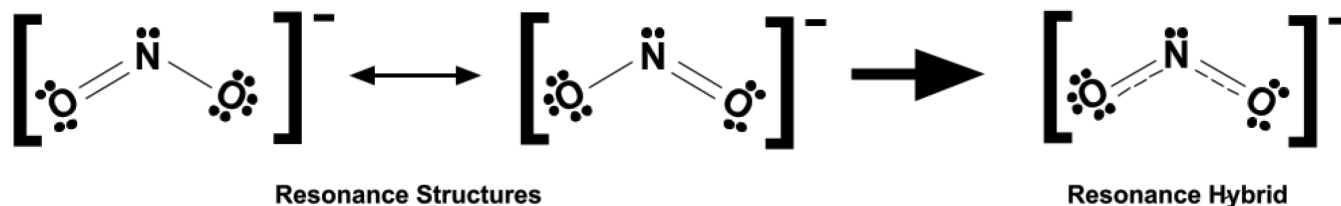



OBJECTIVE 3

Demonstrate an understanding of resonance structures and their relationship to resonance hybrids.

LOCK IT IN:

In the space below, draw the resonance hybrid for the ozone molecule using the resonance structures that you drew.

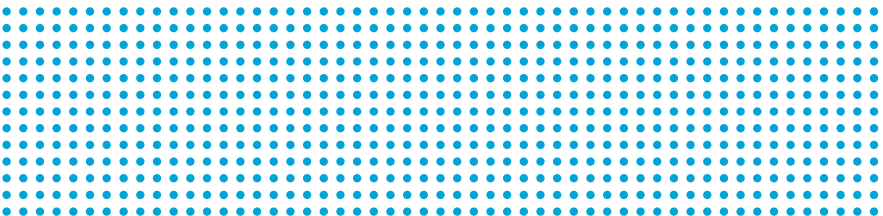
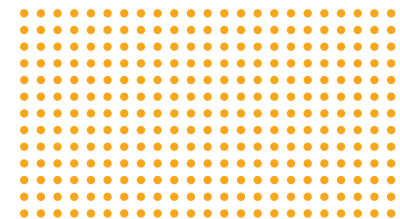



OBJECTIVE 4

Demonstrate an understanding of how formal charge can be used to decide between competing Lewis structures.

TASK 5: Draw three different, valid Lewis structures for the molecule **COS**, known as **carbonyl sulfide**. Make sure carbon is in the center since it is the least electronegative. Once you have made a structure, create it in the sandbox to verify its validity.

Carbonyl Sulfide (COS)

The presence of multiple, seemingly correct Lewis structures certainly complicates the idea of what the molecule actually looks like. As you saw in Task 4, molecules can be a hybrid of their different resonance structures. However, some resonance structures are more stable than others and thus contribute more significantly to the actual structure of the molecule. The tool that allows us to compare the quality of a Lewis structure is known as **formal charge**. A formal charge is the charge given to an atom in a molecule if one assumes that electronegativity is irrelevant and all atoms share the electrons equally. In an ideal situation, the formal charge on atoms is as close to zero as possible.

The formula for calculating the formal charge of an atom in a molecule is as follows:

$$FC = V - N - \frac{B}{2}$$

In the formula, **V** represents the number of valence atoms in that atom, **N** represents the number of nonbonding electrons, and **B** represents the number of bonding electrons. This calculation should be performed for each atom in the molecule.



OBJECTIVE 4

Demonstrate an understanding of how formal charge can be used to decide between competing Lewis structures.

Take a look at the example below of formal charges being calculated for one of the resonance structures for nitrous oxide (N₂O).

Comparing resonance structures requires determining the formal charges for all atoms in all structures and measuring them against the following key rules:

1. The sum of all formal charges in a structure must be equal to the overall charge. The sum of formal charges on a neutral molecule should be zero while the sum should be equal to the charge of an ion.
2. The structure with no formal charges (charges of zero) is typically the best. If there must be formal charges, the smaller the better.
3. When charges must be given, negative formal charge should be on the most electronegative atom.

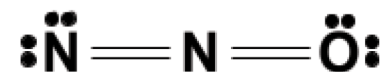

Valence (V):	5	5	6
Nonbonding (N):	4	0	4
Bonding/2 (B/2):	2	4	2
Formal Charge:	-1	+1	0

LOCK IT IN:

Determine the formal charges for each atom of the other resonance structures of nitrous oxide.

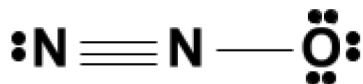

Valence (V):	<input type="text"/>	<input type="text"/>	<input type="text"/>
Nonbonding (N):	<input type="text"/>	<input type="text"/>	<input type="text"/>
Bonding/2 (B/2):	<input type="text"/>	<input type="text"/>	<input type="text"/>
Formal Charge:	<input type="text"/>	<input type="text"/>	<input type="text"/>

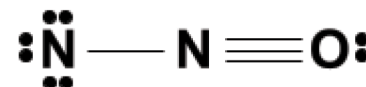

Valence (V):	<input type="text"/>	<input type="text"/>	<input type="text"/>
Nonbonding (N):	<input type="text"/>	<input type="text"/>	<input type="text"/>
Bonding/2 (B/2):	<input type="text"/>	<input type="text"/>	<input type="text"/>
Formal Charge:	<input type="text"/>	<input type="text"/>	<input type="text"/>



OBJECTIVE 4

Demonstrate an understanding of how formal charge can be used to decide between competing Lewis structures.

LOCK IT IN:

Determine which of the three resonance structures that you have seen for N_2O is the most important contributor to the resonance hybrid and draw it in the space below. Once you finish, explain under the heading "Justification" why that structure is the most significant.



JUSTIFICATION



OBJECTIVE 4

Demonstrate an understanding of how formal charge can be used to decide between competing Lewis structures.

TASK 6: Go back to your resonance structures from Task 5 and determine the formal charge of each atom in the structure. Simply write the charge near each atom in your structure as shown in the image below.

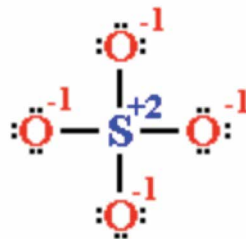

LOCK IT IN:

In the space below, draw the best Lewis structure for carbonyl sulfide by identifying the structure that most closely follows the formal charge rules. Justify your answer beneath the word "Explanation".

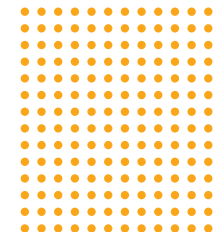

EXPLANATION



OBJECTIVE 5

Demonstrate an understanding of how some molecules violate the octet rule.

TASK 7: Try to make the following two substances in the sandbox. In the space next to them, explain why the sandbox would either not accept the structure that you created or would not allow you to create the structure at all.

Chemical Name	Chemical Formula	Rejection Rationale
Phosphorus pentachloride	PCl_5	
Nitrogen monoxide	NO	

A third substance of interest is known as **borane** (BH_3). Although you are not able to try making this molecule in the sandbox, draw a Lewis structure for it in the space below, then explain why the sandbox would reject it if you could have built it there.

EXPLANATION

The reason the game either rejected or would have rejected the compounds you tried to create is because these compounds fail to meet a key concept in Lewis Theory—the octet rule. However, despite some of them being unstable and short-lived, these compounds and other exceptions like them do exist.



OBJECTIVE 5

Demonstrate an understanding of how some molecules violate the octet rule.

TASK 8: Expanded Octets

Elements in the third period and higher of the periodic table often have expanded octets when they form molecules. These expanded octets can reach up to 14 electrons. Remember that the octet rule is based on an atom typically preferring to have two s and six p electrons in the highest shell. This tells us that the extra electrons of an expanded octet will come from d-orbitals. Since elements in the first and second periods do not have electrons in d-orbitals, they never have expanded octets. Lewis structures for these molecules will have more bonds from the central atom than the four you saw in previous examples.

LOCK IT IN:

Use what you know about expanded octets to draw the Lewis structure for sulfur hexafluoride (SF_6).





OBJECTIVE 5

Demonstrate an understanding of how some molecules violate the octet rule.

TASK 9: Free Radicals

Free radicals are substances whose Lewis structures have an odd number of electrons. As such, free radicals tend to be very unstable and reactive. Lewis structures drawn for free radicals will have single, unpaired nonbonding electrons.

LOCK IT IN:

Use what you know about free radicals to draw the resonance structures for nitrogen dioxide (NO_2). Remember to consider electronegativity when determining where to put the larger number of nonbonding electrons.

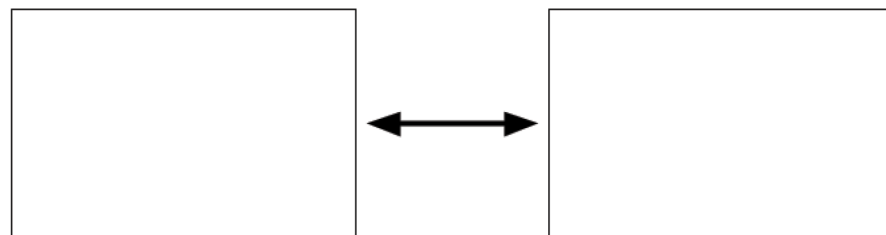

TASK 10: Incomplete Octets

Some elements like boron and aluminum are able to form compounds in which they only have six valence electrons, thus failing to meet the octet rule. These Lewis structures are considered valid even when there are only three bonds connecting boron or aluminum with other elements and no lone pairs on the central atom.

LOCK IT IN:

Use what you know about incomplete octets to draw the Lewis structure for boron trifluoride (BF_3). Avoid making a double bond. Doing so would give fluorine a positive formal charge despite it being very electronegative. Such a resonance structure is likely a very minor contributor.





OBJECTIVE 6

Demonstrate an understanding of how VSEPR theory can be used to predict molecular geometry.

The Valence Shell Electron-Pair Repulsion (VSEPR) Theory is a powerful concept used to determine the three-dimensional shape of numerous molecules and polyatomic ions. It is this theory that is used by the Lewis Structures game to build the final shape of the molecules that you create. VSEPR works by simply considering the electron groups (lone pairs, single bonds, double bonds, triple bonds, and lone electrons) that surround the central atom of a molecule. Since electrons share the same charge, they repel one another. The theory identifies certain geometric structures that minimize the repulsive interactions between these electrons and thus allows us to easily characterize the Lewis structures that we create. Please reference your textbook or lecture notes for more detail on VSEPR Theory.

One method of implementing VSEPR for relatively simple molecules is the **AXE Method**. In this approach, the formula $\mathbf{AX}_m\mathbf{E}_n$ is used where the letter **A** represents the central atom, **X** represents the ligands (atoms bonded to the central atom), and **E** represents nonbonding electron groups (usually a lone pair, but a single electron in the case of free radicals). The subscript *m* indicates the number of ligands and the subscript *n* represents the number of nonbonding electron groups. The $\mathbf{AX}_m\mathbf{E}_n$ notation for a molecule can then be interpreted using a simple table as shown on the next two pages. Look at the AXE approach applied to ammonia below (NH_3):

Ammonia (NH_3)

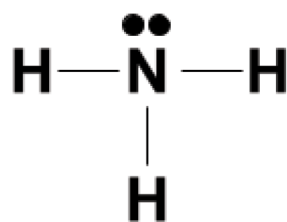

A = N

X = H

$m = 3$

$E_n = 1$

Ammonia = AX_3E_1



OBJECTIVE 6

Demonstrate an understanding of how VSEPR theory can be used to predict molecular geometry.



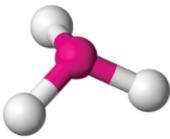
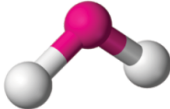
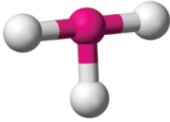
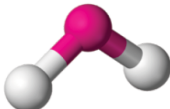
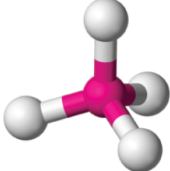
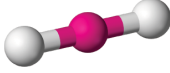
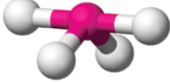
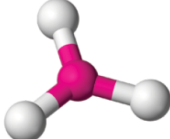
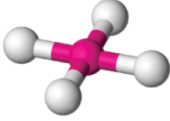

Molecular Geometries

AX_mE_n Notation	Molecular Geometry	Approximate Bond Angles	Structure	AX_mE_n Notation	Molecular Geometry	Approximate Bond Angles	Structure
AX_2E_0	Linear	180°		AX_3E_1	Trigonal Pyramidal	$<109.5^\circ$	
AX_2E_1	Bent	$<120^\circ$		AX_3E_2	T-shaped	$<90^\circ$	
AX_2E_2	Bent	$<109.5^\circ$		AX_4E_0	Tetrahedral	109.5°	
AX_2E_3	Linear	180°		AX_4E_1	Seesaw	$<120^\circ$ (equatorial) $<90^\circ$ (axial)	
AX_3E_0	Trigonal Planar	120°		AX_4E_2	Square Planar	90°	

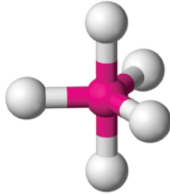
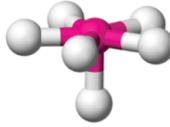
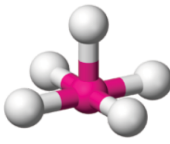

OBJECTIVE 6

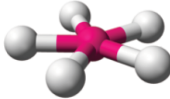
Demonstrate an understanding of how VSEPR theory can be used to predict molecular geometry.

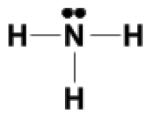
AX_mE_n Notation	Molecular Geometry	Approximate Bond Angles	Structure	AX_mE_n Notation	Molecular Geometry	Approximate Bond Angles	Structure
AX_5E_0	Trigonal Bipyramidal	120° (equatorial) 90° (axial)		AX_6E_1	Pentagonal Pyramidal	72° (equatorial) 90° (axial)	
AX_5E_1	Square Pyramidal	$<90^\circ$		AX_7E_0	Pentagonal Bipyramidal	72° (equatorial) 90° (axial)	
AX_5E_2	Pentagonal Planar	72°		AX_8E_0	Square antiprismatic	$70.5^\circ, 99.6^\circ$ and 109.5°	
AX_6E_0	Octahedral	90°		<p>Ammonia (NH_3)</p>  <p> $A = N$ $X = H$ $m = 3$ $E_n = 1$ </p> <p>Ammonia AX_3E_1 → Trigonal Pyramidal</p>			

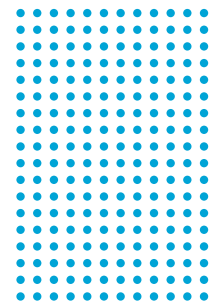



OBJECTIVE 6

Demonstrate an understanding of how VSEPR theory can be used to predict molecular geometry.

TASK 11: Complete the table below by creating the Lewis structure for each molecule listed before determining its AX_mE_n notation and molecular geometry. **Check your first two answers with the sandbox to make sure you are on the right track. Keep your eyes open for expanded octets!**

Chemical Name	Chemical Formula	Lewis Structure	AX_mE_n Notation	Molecular Geometry
Hydrogen Sulfide	H ₂ S			
Phosphorus Trichloride	PCl ₃			
Xenon Tetrafluoride	XeF ₄			
Bromine Pentafluoride	BrF ₅			



OBJECTIVE 6

Demonstrate an understanding of how VSEPR theory can be used to predict molecular geometry.

LOCK IT IN:

Explain why the sandbox game gave the molecule below the molecular geometry it did.

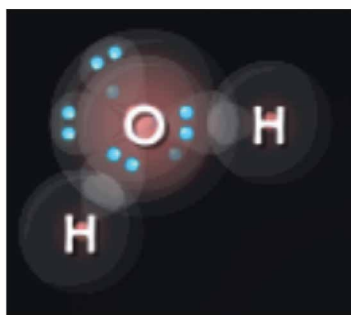

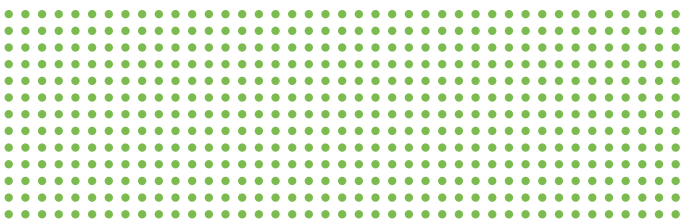
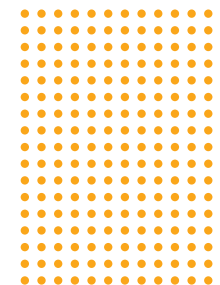



OBJECTIVE 7

Demonstrate an understanding of how electronegativity differences can be used to classify bonds.

Another key concept in chemical bonding is **electronegativity**. Electronegativity describes the tendency of an atom to attract shared electrons towards itself. The difference in electronegativity between two bonded elements can help reveal whether the bond is ionic, nonpolar covalent, or polar covalent. Metals tend to have very low electronegativities while nonmetals tend to have higher ones. Ionic bonds, which form between metals and nonmetals, are thus characterized by large differences in electronegativities between the bonding elements. Nonmetals tend to have smaller electronegativity differences between them, and thus their electrons are shared instead of transferred. As you saw in the game, the electronegativity differences between nonmetals can still be enough that electrons spend more time around the more electronegative atom. These unequal bonds are considered **polar covalent bonds**.

Pauling Electronegativities of the Elements

Group (vertical)	1	2	3	4	5	6	7	8	9	10	11	12	13	14	15	16	17	18
Period (horizontal)																		
1	H 2.20																	He
2	Li 0.98	Be 1.57											B 2.04	C 2.55	N 3.04	O 3.44	F 3.98	Ne
3	Na 0.93	Mg 1.31											Al 1.61	Si 1.90	P 2.19	S 2.58	Cl 3.16	Ar
4	K 0.82	Ca 1.00	Sc 1.36	Ti 1.54	V 1.63	Cr 1.66	Mn 1.55	Fe 1.83	Co 1.88	Ni 1.91	Cu 1.90	Zn 1.65	Ga 1.81	Ge 2.01	As 2.18	Se 2.55	Br 2.96	Kr 3.00
5	Rb 0.82	Sr 0.95	Y 1.22	Zr 1.33	Nb 1.6	Mo 2.16	Tc 1.9	Ru 2.2	Rh 2.28	Pd 2.20	Ag 1.93	Cd 1.69	In 1.78	Sn 1.96	Sb 2.05	Te 2.1	I 2.66	Xe 2.60
6	Cs 0.79	Ba 0.89	*	Hf 1.3	Ta 1.5	W 2.36	Re 1.9	Os 2.2	Ir 2.20	Pt 2.28	Au 2.54	Hg 2.00	Tl 1.62	Pb 2.33	Bi 2.02	Po 2.0	At 2.2	Rn 2.2
7	Fr 0.7	Ra 0.9	**	Rf	Db	Sg	Bh	Hs	Mt	Ds	Rg	Uub	Uut	Uuq	Uup	Uuh	Uus	Uuo
Lanthanides	*	La 1.1	Ce 1.12	Pr 1.13	Nd 1.14	Pm 1.13	Sm 1.17	Eu 1.2	Gd 1.2	Tb 1.1	Dy 1.22	Ho 1.23	Er 1.24	Tm 1.25	Yb 1.1	Lu 1.27		
Actinides	**	Ac 1.1	Th 1.3	Pa 1.5	U 1.38	Np 1.36	Pu 1.28	Am 1.13	Cm 1.28	Bk 1.3	Cf 1.3	Es 1.3	Fm 1.3	Md 1.3	No 1.3	Lr 1.291		

Electronegativity Values, [CC BY-SA 3.0](#)



OBJECTIVE 7

Demonstrate an understanding of how electronegativity differences can be used to classify bonds.

Electronegativity Difference	Bond Type
< 0.4	Nonpolar Covalent
0.4 to 1.7	Polar Covalent
> 1.7	Ionic if between metal and nonmetal, but polar covalent if not

TASK 12: Use the electronegativity values and bond type table provided above to classify each bond in the table below as either nonpolar covalent or polar covalent.

Chemical Bond	Electronegativity of First Element	Electronegativity of Second Element	Electronegativity Difference	Polar or Nonpolar
C—C				
C—H				
H—F				
Br—F				
P—Cl				



OBJECTIVE 7

Demonstrate an understanding of how electronegativity differences can be used to classify bonds.

LOCK IT IN:

Look at the image below of hydrogen fluoride made in the sandbox. What method does the game use to show the polarity of the bond? How does this reflect the electronegativity difference of this bond that you calculated in Task 12?

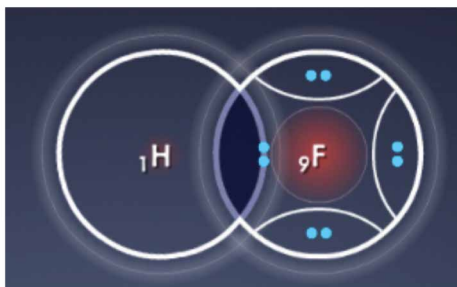

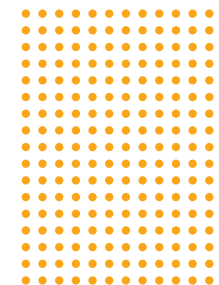



OBJECTIVE 8

Demonstrate an understanding of how the polarity of a molecule is determined by both molecular geometry and the polarity of its bonds.

Interestingly enough, a molecule composed of only polar bonds can be considered nonpolar. This is because both the polarity of bonds within the molecule and its molecular geometry are necessary for determining the overall polarity of a molecule.

In order to understand how this works, one must understand the concept of a **bond dipole moment**. This concept is simply an extension of the bond polarity that you explored in Task 12. Bonded atoms often do not share electrons equally, and when this happens the bond is said to exhibit a dipole moment. This dipole moment can be represented by a vector (arrow) pointing from the less electronegative element to the more electronegative one. The now slightly more positive atom receives the label δ^+ while the slightly more negative one receives the label δ^- . Look at the examples with boron and fluorine below.

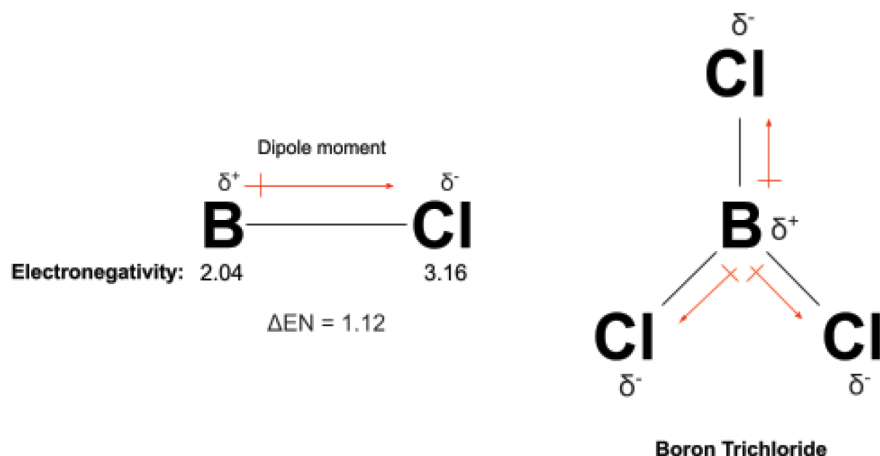

However, individual dipole moments can cancel each other out depending on the shape of the molecule. It is for this reason that it is important to determine the **net dipole moment** for the molecule by considering the sum of all individual dipole moments created by polar bonds. In fact, boron trichloride above is nonpolar despite having three polar bonds. Please reference your textbook or lecture notes for a deeper understanding of polarity before continuing.



OBJECTIVE 8

Demonstrate an understanding of how the polarity of a molecule is determined by both molecular geometry and the polarity of its bonds.

Consider silicon dioxide and sulfur dichloride. Notice that both contain polar bonds, but only the molecular geometry of sulfur dichloride allows for a net dipole moment. As a result, the fully symmetrical silicon dioxide is a nonpolar molecule and sulfur dichloride is a polar one.

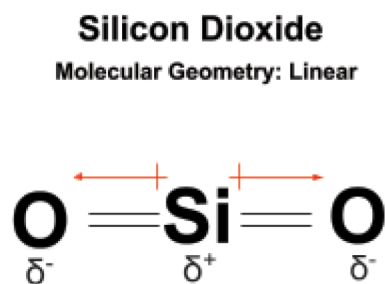
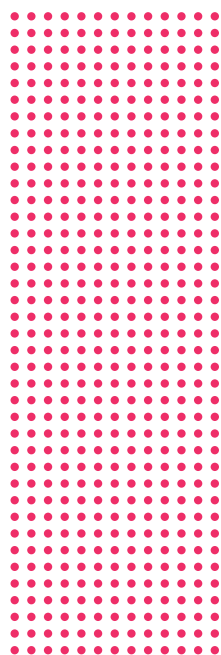

Dipoles Cancel
Each Other Out

Nonpolar Molecule

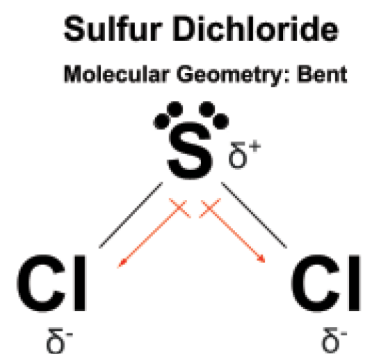

Dipoles Do Not Fully Cancel
Net Dipole Moment Present

Polar Molecule

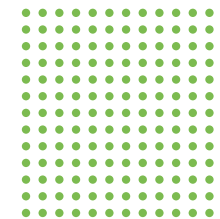



OBJECTIVE 8

Demonstrate an understanding of how the polarity of a molecule is determined by both molecular geometry and the polarity of its bonds.

Consider chloromethane (CH_3Cl). Although the molecular geometry of the structure (tetrahedral) is symmetrical, due to its composition it has one polar bond that is not canceled out by other equally polar bonds in the opposite directions. Compare it to carbon tetrachloride (CCl_4) whose four polar bonds cancel each other out.

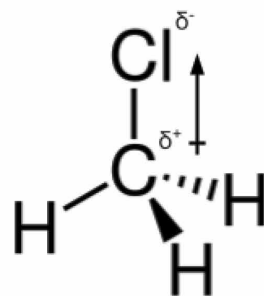
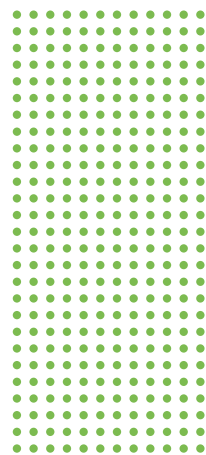

Net Dipole Moment

Polar Molecule

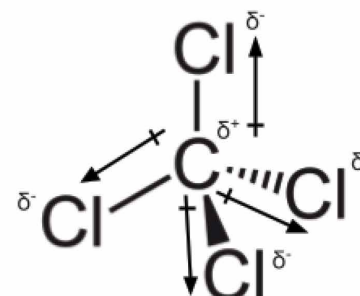

Dipoles Cancel Out

Nonpolar Molecule

Determining whether a molecule is polar requires a few steps:

1. Draw a Lewis structure for the molecule.
2. Determine if the molecule has any polar bonds using electronegativities. A molecule without any polar bonds is **nonpolar**.
3. Determine the molecular geometry of the structure. If the atoms attached to the central atom are all the same, then molecules of the following geometries will be **nonpolar** due to their symmetry:
 - Linear
 - Trigonal Planar
 - Square Planar
 - Tetrahedral
 - Trigonal Bipyramidal
 - Octahedral
4. If the molecule has at least one polar bond and the atoms bonded to the central atom are not identical, the molecule is probably **polar**.
5. Assess the sum of the individual dipoles. If all polar bonds are countered by bonds equal in magnitude and opposite direction, then they will cancel out. Such molecules are **nonpolar**. In the case that a net dipole remains, the molecule is **polar**.



OBJECTIVE 8

Demonstrate an understanding of how the polarity of a molecule is determined by both molecular geometry and the polarity of its bonds.

TASK 13: Determine if the molecules in the table are polar or nonpolar. When possible, check your Lewis structure and molecular geometry by building the molecule in the sandbox before determining if it is polar or nonpolar.

Chemical Name	Chemical Formula	Lewis Structure (Labeled with Dipole Arrows and δ^+/δ^-)	AX_mE_n Notation	Molecular Geometry	Polar or Nonpolar?
	XeF ₂				
	OF ₂				
	IF ₅				
Fluoromethane	CH ₃ F				



OBJECTIVE 8

Demonstrate an understanding of how the polarity of a molecule is determined by both molecular geometry and the polarity of its bonds.

LOCK IT IN:

Is this molecule polar or nonpolar? Justify your answer.

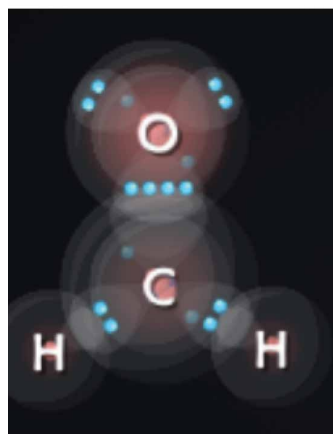

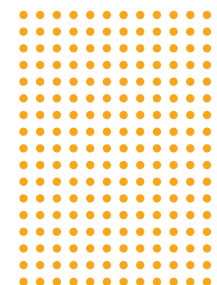



CLOSURE

CLOSURE: Complete the rest of the spaces in the table for the molecule whose chemical formula is provided.

Hint: One of your resonance structures will show an expanded octet of ten electrons, while the other two will not.

Chemical Formula	Chemical Name	Resonance Structure #1 (Labeled with Formal Charges)	Resonance Structure #2 (Labeled with Formal Charges)
SO ₂			
Resonance Structure #3 (Labeled with Formal Charges)	Most Stable Resonance Structure (Labeled with Formal Charges)	Resonance Hybrid	AX _m E _n Notation
Molecular Geometry	Resonance Hybrid (Depicting Molecular Geometry & Labeled with Dipole Arrows and δ ⁺ /δ ⁻)	Polar or Nonpolar?	